

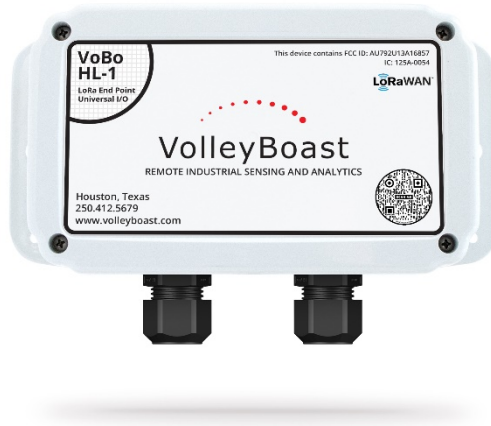

# VolleyBoast

## INSTALLATION MANUAL

# VoBo HL-1









The VoBo HL-1 is an industrial grade LoRaWAN endpoint that is certified to be located in Hazardous Areas. The HL-1 converts wired industrial sensors and transmitters into wireless sensors and has the following key features:

- Provides three analog inputs, three discrete digital inputs, one “wake-up” input, one RS-485 input (for Modbus RTU devices), and one open drain output.
- Two entry points for sensor cables are provided. The HL-1 comes equipped with 2 installed cord grips and a hole plug. The entry points also accept ½ inch conduit fittings.
- IP 66 rated and has an operating temperature range of -35° C to 80° C.
- Expected battery life under normal operating conditions is 2 to 4 years.
- Range is up to 10 miles line-of-site to any LoRaWAN compliant gateway.
- The datasheet is available here:  
<https://www.volleyboast.com/products/vobohl1/support/>

## CONTENTS

<b>WARNINGS .....</b>	<b>3</b>
<b>VOBO HL-1 COMPONENT OVERVIEW .....</b>	<b>4</b>
Description of Components .....	5
<b>SETTING UP.....</b>	<b>7</b>
Arranging the Jumpers.....	7
Field Installation.....	8
Maintenance .....	10
<b>REGULATORY INFORMATION .....</b>	<b>10</b>
Hazard Class Information.....	10
47 CFR Part 15 Regulation Class B Devices .....	11
FCC Interference Notice.....	11
Industry Canada Class B Notice.....	12
Industry Canada .....	12
<b>CONTROL DRAWING (ANALOG CIRCUITS).....</b>	<b>14</b>
<b>CONTROL DRAWING (DIGITAL CIRCUITS).....</b>	<b>15</b>
<b>REVISION HISTORY .....</b>	<b>16</b>
<b>CONTACT INFORMATION .....</b>	<b>16</b>

## WARNINGS

-  **WARNING:** Do not install the device in hazardous locations exceeding the rated hazard classifications, as shown in the Regulatory Information section of this document.
-  **WARNING:** Before opening the enclosure, take the appropriate antistatic precautions, such as discharging your electrostatic potential by touching a known grounded object, or using an antistatic wrist strap.
-  **WARNING: Explosion Hazard when equipment is not handled properly or not installed correctly.** All installation and maintenance of the VoBo HL-1 device may only be performed by trained personnel authorized by the facility. Personnel must fully read and understand this document before carrying out the instructions. All warnings must be heeded.
-  **WARNING:** Do not clean the device with a dry cloth, at risk of electrostatic discharge.
-  **WARNING:** To maintain the IP66 rating the enclosure cover screws must be tightened to 8.00 in-lbs. Do not overtighten the screws. The entry point fittings (cord grips or conduit fittings) must be rated IP66 or better and installed in accordance with the manufacturer's instructions.
-  **WARNING:** Dispose of the battery properly according to local laws and regulations.
-  **WARNING:** Installation of a different antenna than the one contained in the VoBo HL-1 is not permitted.

ANSI/ISA 12.12.01 and CAN/CSA C22.2 No.213:  
Class I, Division 2, Groups C,D T4  
Class II, Division 2, Groups F,G T135 °C



UL-62368-1, Third Edition  
CSA C22.2 No. 62368-1, Third Edition  
Annex Y





## Description of Components

<b>Cover</b>	The VoBo HL-1 is rated to IP66. These standards require that the gasket be properly positioned, and the cover screws tightened to 8.00 in-lbs. Do not over tighten the screws.
<b>Entry Points</b>	<p>The VoBo HL-1 has two (2) 7/8-inch diameter entry holes. Two cord grips (cable glands) are provided. The cord grips accept 0.095-inch to 0.290-inch diameter cable. For cable that is of a larger diameter, alternate cable glands may be installed by the user, providing that they are rated watertight and to a -40° C to 80° C temperature range and they are installed in accordance with the manufacturer’s specifications. One (1) hole plug is provided. This may be installed in place of one of the cable glands if only one entry point is utilized.</p> <p>To connect sensors other than certified non-incendive sensors, the user may remove the provided cord grip(s) and install conduit fittings in accordance with the requirements of the National Electric Code (NFPA70) or the Canadian Electrical Code (CSA C22.1) and all local codes and regulations.</p>
<b>Battery Holder</b>	<p>A 13 Ahr Saft LSH20 D-size Underwriters Laboratories (UL) recognized lithium-thionyl chloride [Li-SOCl<sub>2</sub>] primary cell is provided. Users can replace the battery with one of the following cells:</p> <p style="text-align: center;">Saft LSH20 Saft LS 33600 TadiranTL-2300 Tadiran TL-5930</p> <p>The battery <b>MUST BE</b> installed with the correct polarity. The polarity is marked adjacent to the battery holder. The Power Switch must first be switched to the “OFF” position while inserting or removing a battery.</p> <p>A Velcro tie down strip is provided to ensure the battery remains in place during transportation.</p>
<b>Power Switch</b>	<p>The switch activates/deactivates the power supply (the battery).</p> <p>It should be in the “OFF” position when installing or removing the battery. The power slider switch can also be used to reboot the microprocessor.</p>
<b>LED</b>	The LED indicates successful completion of firmware initialization after power is turned on and successful connection to the network has been made.
<b>WUP Switch</b>	<p>Press this button briefly to interrupt the preprogrammed sleep/wake cycle. This will immediately initiate the programmed reading of connected sensors and transmission of payload. This is useful for checking readings while in the field or when calibrating sensors.</p> <p> The WUP switch will not function if the WUP terminal circuit is closed</p>
<b>MAGNETIC WUP</b>	There is a magnetic switch directly underneath this label. When the enclosure cover is on, a magnet can be used to activate this switch and interrupt the preprogrammed sleep/wake cycle. This will immediately initiate the programmed reading of connected

	<p>sensors and transmission of payload. A red dot has been affixed to the exterior of enclosure marking the location of the magnet.</p> <p> The Magnetic WUP switch will not function if the WUP terminal circuit is closed.</p>
<b>AI1, AI2, AI3</b>	<p>Analog terminal blocks. Each is jumper configurable for reading 4-20mA, 0-5V, or 0-10V sensors/transmitters. The terminal blocks accept 28-16AWG stranded or solid wires. Wire strip length should be 0.2 in (5-6 mm).</p>
<b>DI1, DI2, DI3</b>	<p>Discrete input terminals. Use DI3 for pulse counting. Pulse counting requires custom software. Contact VolleyBoast to obtain the software. Any of the discrete inputs may be used for monitoring switches. The discrete terminals can be individually configured to act as dry contact or voltage. The terminal blocks accept 28-16AWG stranded or solid wires. Wire strip length should be 0.2 in (5-6 mm).</p>
<b>WUP Terminal</b>	<p>Can be used to connect an external dry contact switch. When the switch position is changed (open/closed) the VoBo will wake up, run through its program, read any connected sensors, and transmit the data. The terminal blocks accept 28-16AWG stranded or solid wires. Wire strip length should be 0.2 in (5-6 mm).</p>
<b>DOUT</b>	<p>An open drain output terminal. Used to communicate with external devices.</p>
<b>RS485</b>	<p>An RS-485 terminal. Used for communicating with Modbus RTU devices.</p>
<b>SERIAL</b>	<p>A RS232/UART terminal. Used for recovering logged data and performing local configuration of the VoBo.</p> <p> The area must be free of hazardous gases or materials prior to connecting any device that is not certified for operation in the hazardous area to the VoBo HL-1.</p>
<b>SERIAL Switch</b>	<p>The switch used to enable or disable communication with the processor through the Serial terminal.</p>
<b>X6 thru X19</b>	<p>Jumpers used to configure analog terminals.</p>
<b>X21 thru X29</b>	<p>Jumpers used to configure DI1 thru DI3 terminals.</p>
<b>X5</b>	<p>JTAG connection. Not for customer use.</p>
<b>JP4</b>	<p>The Jumper can be closed to connect the shield circuit to ground. Normally it is left open.</p>
<b>JP3</b>	<p>Jumper can be closed to add a Termination Resistor (143 ohms) to the RS-485 circuit.</p>

 The WUP button and Magnetic switch only function when the WUP I/O terminal is not in a closed position.

## SETTING UP

### Arranging the Jumpers

Each input terminal is associated with a set of jumpers. Note: the jumpers are not positioned directly in front of their associated terminal. The terminals and their associated jumpers are shown below. The position of the jumpers is indicated for the various sensor types. The red boxes indicate which pins should be connected (i.e., closed) with a jumper.

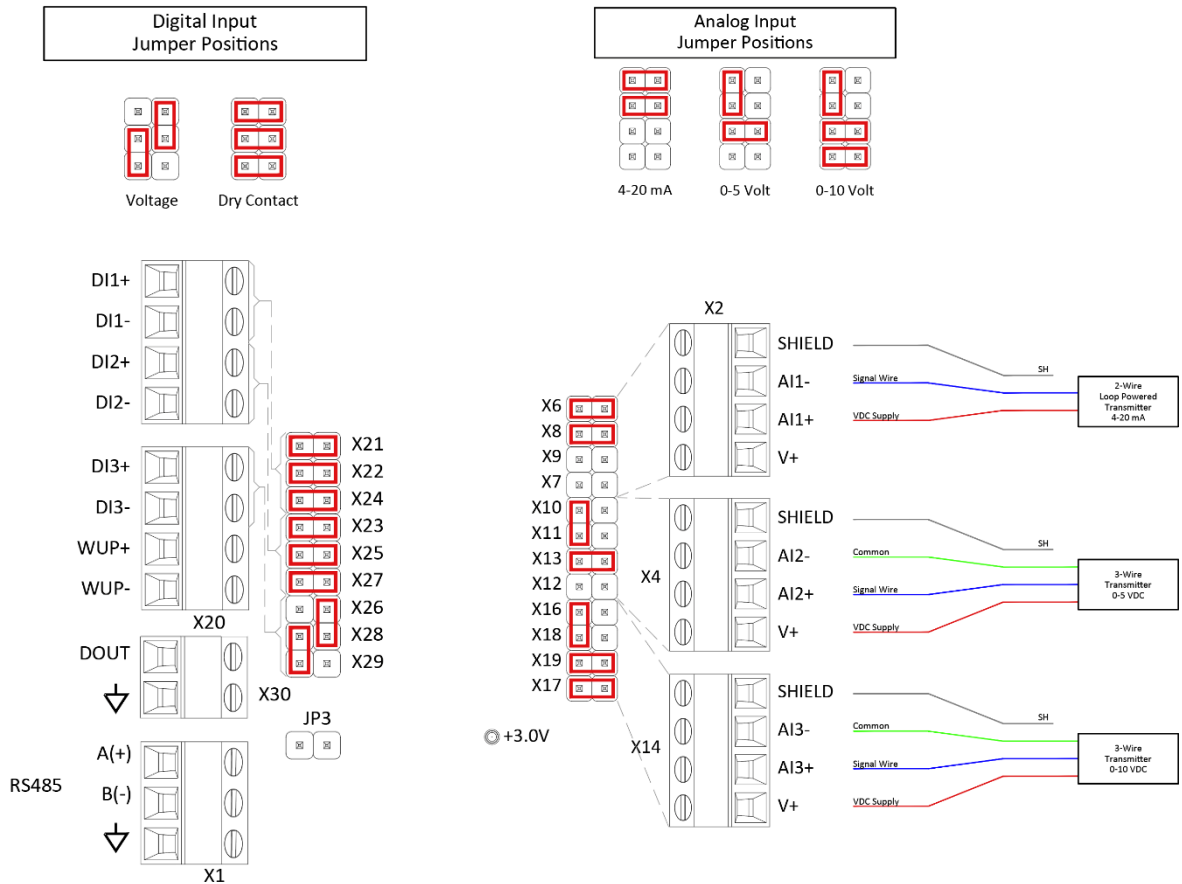

#### Discrete Terminals (Digital Input)

When the jumpers are arranged for dry contact, and the circuit between the positive and negative terminal is closed (ex. reed switch) or opened the circuit will report its state in the payload. When the jumpers are arranged in the voltage position, the circuit will report the presence of an externally applied voltage across the positive and negative terminals. Note: Pulse counting should be done through the DI3 terminal. Contact VolleyBoast to obtain pulse counting software.

Note: jumpers X21, X22, and X24 correlate to DI1, X23, X25, and X27 correlate to DI2, and X26, X28, and X29 correlate to DI3.

#### WUP Terminal

The WUP terminal accepts a dry contact switch. It will initiate the VoBo’s routine as soon as the circuit changes from open to closed, or vice versa.





### RS-485 Terminal

The RS-485 terminal has one jumper (JP3). Closing jumper JP3 adds a 143 Ohm termination resistor to the circuit.

### Jumper JP4

When Jumper JP4 is closed it connects the Shield circuit to the Ground circuit.

## Field Installation

-  **Do not remove or replace sensors or cabling unless the Power Switch is set to “Off” position.**
-  **Do not connect multiple sensors in parallel with each other.**
-  **Sensors and cabling to be installed in accordance with the VoBo HL-1 Control Drawing # DWG-0023 (attached).**
-  **The VoBo GP-1 must be installed a minimum of 20 cm away from personnel.**

Turn the POWER switch to the OFF position.

Remove any unnecessary cord grips. Install the provided hole plug into the unused hole by inserting the plug into the cord grip nut and tighten it to a torque of 40-45 in.lbs.

Ensure the sensor wires are stripped to 0.2 in (5-6 mm). Insert the sensor cable into the cord grip. The cord grips accept cable diameters of between 0.095 inch and 0.290 inch. The VoBo HL-1 cord grip sealing nut should be tightened to a torque of 50-55 in.lbs. If different cord grips or conduit fittings are desired, the installed cord grips may be replaced by the user with alternate fittings. The alternate fittings must be rated to provide a watertight seal around the cable and the enclosure opening.

The VoBo HL-1 should be mounted on a secure, rigid surface capable of supporting the VoBo and sensor cables. Use 4 - #8 pan head machine bolts or wood screws, depending upon the material of the mounting surface, to attach the VoBo to the surface. If mounting to a wood surface, the screws should be one inch in length. If mounting in a location that would subject the VoBo to corrosive elements, use stainless or galvanized screws/bolts.

 **To maintain the VoBo HL-1 hazardous location certification and IP66 protection, the entry points to the device must be sealed so they are watertight.**

Connect the sensor wires as described below.

### Analog Sensors

The table below provides the maximum analog terminal current output (total):



Voltage Setting (V)	5	6	8	10	12	14	16	18	20	22	24
Max Current (mA)	228	181	127	98	80	67	58	51	45	41	37

 **Drawing current from the analog terminal blocks in greater amounts may damage the VoBo.**

4-20mA sensor

- Two-wire loop powered sensor: insert the VDC supply wire (typically red) in the AI+ and the signal wire (typically black) in AI- of the analog input terminal block. Bare or shield goes into SH.

Voltage sensors

- Insert the VDC supply wire (typically red) in the V+ and the signal out (typically black) wire in AI+, and the ground wire in AI- of the analog input terminal block.

Discrete Sensors (Switches, pulse counters, etc.)

- Insert the plus and minus wires in the D+ and D- connections.

Modbus RTU Sensor

The VoBo has an RS-485 serial port for Modbus RTU sensors. It is programmed to read and transmit one 16-bit register. Please contact VolleyBoast to poll multiple tags or if your register is larger than 16-bits.

The VoBo Modbus RTU communication parameters are “8N1”.

Data bits = 8

Parity = N

Stop bits = 1

The VoBo can transmit Modbus sensor data for sensors powered both externally as well as by the VoBo. In both powering scenarios, the signal wires are connected to the RS-485 terminal. A Modbus sensor can be powered through the V+ connection on the analog terminal block.

Connect the RX, TX, and Ground wires of the Modbus sensor to the respective RS-485 terminals. If the VoBo is powering the sensor, connect the voltage supply wire to an analog V+ terminal and the shield wire to the SH terminal.

Note that closing jumper JP3 allows for reading multiple Modbus devices. JP3 is normally left open when reading a single device. Custom programming is required to read multiple Modbus devices.

Once the jumpers are configured and the sensors installed, turn the “POWER” slider switch to “ON”.

Check LED for status. The LED will light green for 1 second following successful initialization of the VoBo. The LED will briefly flash green each time the VoBo attempts to join the network. The LED will light green for 1 second upon successfully joining the network and receiving a confirmation back from the gateway. The LED will light red for 1 second if it fails to join the network after 10 attempts. The LED flashes red if the VoBo fails to receive an acknowledgement back from the Gateway (after it has joined and sent a payload).

Press the WUP button to send another payload to confirm connectivity and transmission. Note the LED only functions upon powering up the VoBo. It will not light under normal operation.

From this point forward the payload and sensor readings should be sent to your LoRaWAN network server and, assuming it is set up, you should be able to ascertain the sensor readings from the network.

Attach the VoBo cover with the provided screws. The screws should be tightened to 8 in-lbs. Holding the screwdriver with just your thumb and first two fingers and then torqueing the screwdriver seems to approximate 8 in-lbs.

Note: if you want to test the VoBo at different locations for connectivity/signal strength, the VoBo is programmed to transmit temperature and battery voltage without connecting to external sensors. The Network Server will likely report signal strength from the endpoint. In this manner you can assess the quality of connectivity at different locations.

Problems? Contact VolleyBoast at: [support@volleyboast.com](mailto:support@volleyboast.com)

## Maintenance

User maintenance requirements of the VoBo HL-1 is limited to replacing a depleted battery with a fresh battery. Please contact VolleyBoast if any issues arise with respect to the performance of the VoBo HL-1.

## REGULATORY INFORMATION

### Hazard Class Information

ANSI/ISA 12.12.01 and CAN/CSA C22.2 No.213:

CLASS I, DIVISION 2, GROUPS C, D T4

Flammable gases including Ethylene, Propane, and Methane

CLASS II, DIVISION 2, GROUPS F, G T135 °C

Combustible dusts including metal dusts, carbonaceous dusts, flour, grain, wood, plastics, and chemicals

CLASS III, DIVISION 1

Combustible fibers and flyings

## 47 CFR Part 15 Regulation Class B Devices

This equipment has been tested and found to comply with the limits for a Class B digital device, pursuant to part 15 of the FCC Rules. These limits are designed to provide reasonable protection against harmful interference in a residential installation. This equipment generates, uses, and can radiate radio frequency energy and, if not installed and used in accordance with the instructions, may cause harmful interference to radio communications. However, there is no guarantee that interference will not occur in a particular installation. If this equipment does cause harmful interference to radio or television reception, which can be determined by turning the equipment off and on, the user is encouraged to try to correct the interference by one or more of the following measures:

- Reorient or relocate the receiving antenna.
- Increase the separation between the equipment and receiver.
- Connect the equipment into an outlet on a circuit different from that to which the receiver is connected.
- Consult the dealer or an experienced radio/TV technician for help.

Warning: Changes or modifications to this unit not expressly approved by the party responsible for compliance could void the user's authority to operate the equipment.

## FCC Interference Notice

Per FCC 15.19(a)(3) and (a)(4) This device complies with part 15 of the FCC Rules. Operation is subject to the following two conditions:

1. This device may not cause harmful interference
2. This device must accept any interference received, including interference that may cause undesired operation.

### FCC Grant

FCC Part 15	
FCC Identifier:	AU792U13A16857
Equipment Class:	Digital Transmission System
Notes:	MTDOT-915
FCC Rule Parts:	15C
Approval:	Single Modular
Frequency Range:	902.3-914.9
Output Watts:	0.0772

Output power is conducted. This transmitter is a hybrid per FCC 15.247(f) and FCC KDB 453039. The antenna(s) used for this transmitter must be installed to provide a separation distance of at least 20 cm from all persons and must not be collocated or operating in conjunction with any other antenna or transmitter within a host device, except in accordance with FCC multi-transmitter product procedures.

## Industry Canada Class B Notice

This Class B digital apparatus meets all requirements of the Canadian Interference-Causing Equipment Regulations.

*Cet appareil numérique de la classe B respecte toutes les exigences du Règlement Canadien sur le matériel brouilleur.*

This device complies with Industry Canada license-exempt RSS standard(s). The operation is permitted for the following two conditions:

1. The device may not cause interference.
2. This device must accept any interference, including interference that may cause undesired operation of the device.

*Le présent appareil est conforme aux CNR d'Industrie Canada applicables aux appareils radio exempts de licence. L'exploitation est autorisée aux deux conditions suivantes:*

1. *L'appareil ne doit pas produire de brouillage*
2. *L'appareil doit accepter tout brouillage radioélectrique subi, même si le brouillage est susceptible d'en compromettre le fonctionnement.*

## Industry Canada

Specification/ Cahier des Charges	Issue/ Édition	From Frequency/ De Fréquences	To Frequency/ À Fréquences	Emmission Designation/ Designation D'émission	Minimum Power	Maximum Power
RSS247	1.0	902.3 MHz	914.9 MHz	GXDXX	77.2 mW	77.2 mW

Certification Number/No. de Certification	125A-0054
	Modular Approval/Approbation modulaire
Model/Modèle	MTDOT-915

Certification of equipment means only that the equipment has met the requirements of the above noted specification. License applications, where applicable to use certified equipment, are acted on accordingly by the Industry Canada issuing office and will depend on the existing radio environment, service and location of operation. This certificate is issued on condition that the holder complies and will continue to comply with the requirements and procedures issued by Industry Canada. The equipment for which this certificate is issued shall not be manufactured, imported distributed, leased, offered for sale or sold unless the equipment complies with the applicable technical specifications and procedures issued by Industry Canada.

*La certification du matériel signifie seulement que le matériel a satisfait aux exigences de la norme indiquée ci-dessus. Les demandes de licences nécessaires pour l'utilisation du matériel certifié sont traitées en 13pecificati par le bureau de délivrance d'Industrie Canada et 13pecifica des conditions radio ambiantes, du service et de l'emplacement d'exploitation. Le 13pecifi 13pecificati est délivré à la condition que le titulaire satisfasse et continue de satisfaire aux exigences et aux 13pecificat d'Industrie Canada. Le matériel à l'égard duquel le 13pecifi 13pecificati est délivré ne doit pas être fabriqué, importé, distribué, loué, mis en vente ou vendu à moins d'être conforme aux 13pecificat et aux 13pecifications techniques applicable publiées par Industrie Canada.*

# CONTROL DRAWING (ANALOG CIRCUITS)

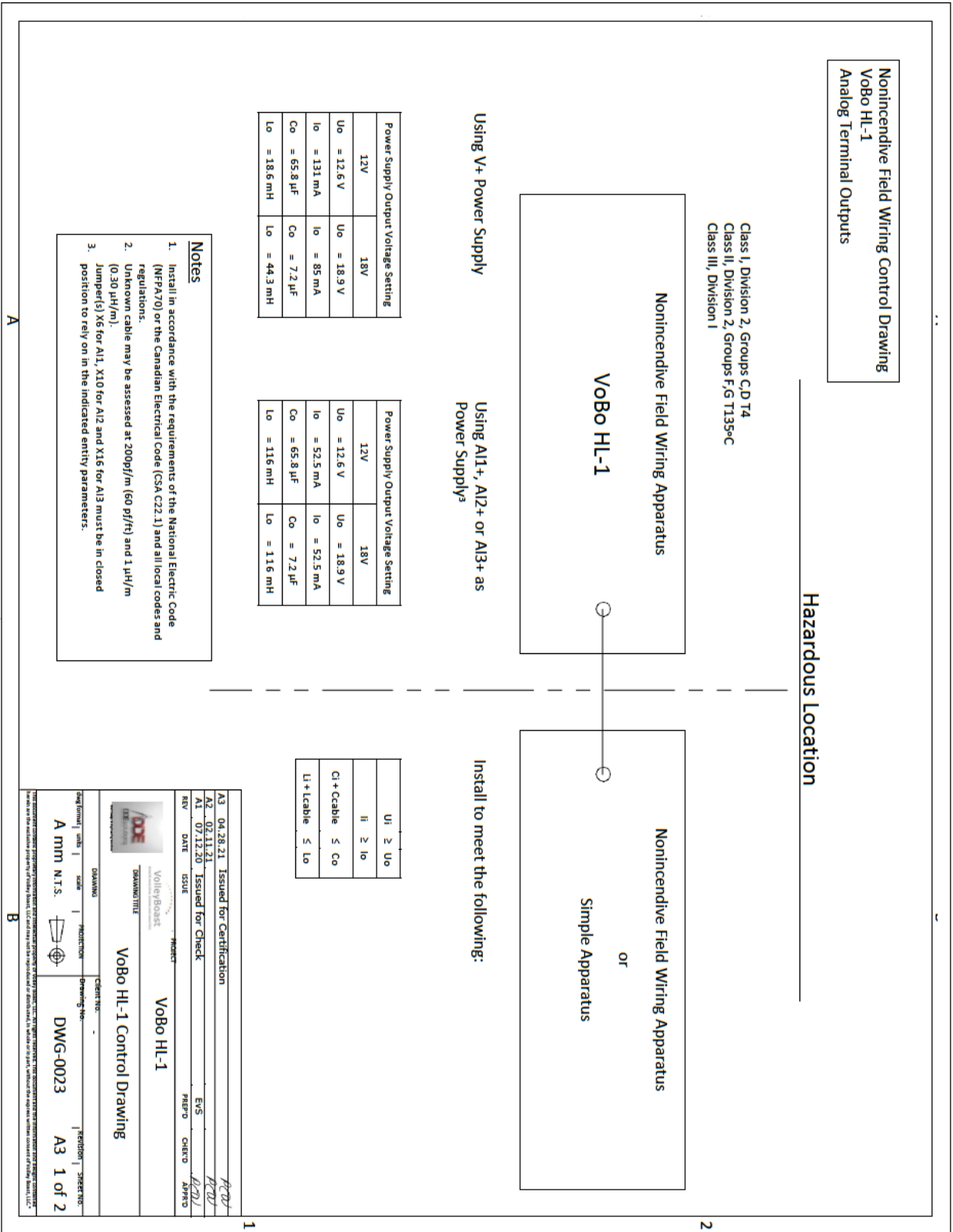

# CONTROL DRAWING (DIGITAL CIRCUITS)

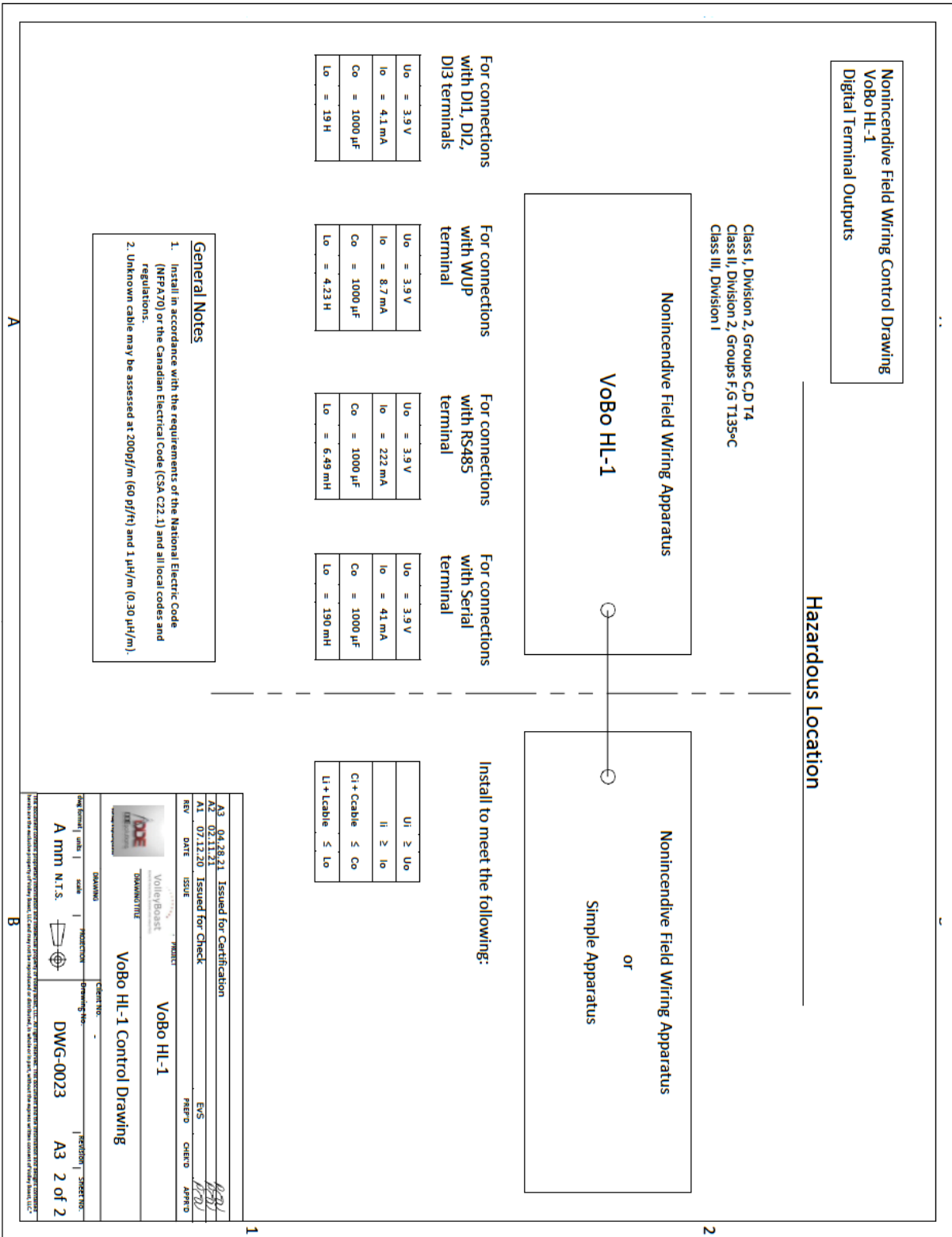

## REVISION HISTORY

Revision Date	Section	Revision
2021-02-09	Description of Components	Added specific permitted replacement batteries
2021-03-25	Control Drawing	Revised to include revision A2
2021-04-28	Control Dwg & related info	Operating Temp, HazLoc ratings revised

## CONTACT INFORMATION

(+1) 250-412-5679

[info@volleyboast.com](mailto:info@volleyboast.com)

[www.volleyboast.com/](http://www.volleyboast.com/)

2000 North Loop West, Suite 120

Houston, TX 77018